

WMF COFFEE MACHINES

Data sheet for Presto series 1400

<p>The article numbers in the table represent only a cross-section of the complete range of articles</p>	<p>03 1400 0002 Presto 1 / N / PE, 50Hz, 230V, 2.2 kW, fuse protection building 10 A, integrated milk foamer, fixed water connection 1/2", drain DN 19, 2 coffee grinders, 1 chocolate powder dispenser, integrated thermoelectric refrigerator (Peltier refrigeration) 1.5 L milk container, hot water and steam dispenser, espresso, café crème, cappuccino, latte macchiato, chococcino, drinking chocolate, dual drain 70-190 mm, amber lighting</p>
<p>The WMF Presto series is a modular system and can be customised for the requirements of the customer.</p>	<p>03 1400 0006 Presto 1 / N / PE, 50Hz, 230V, 2.2 kW, fuse protection building 10 A, integrated milk foamer, water tank 4.5 L, 1 coffee grinder, hand insertion, hot water dispenser, espresso, café crème, cappuccino, latte macchiato, dual drain 70 – 190 mm,</p>
	<p>03 1400 0021 Presto 1 / N / PE, 50Hz, 230V, 2.2 kW, fuse protection building 10 A, water tank 4.5 L, 1 coffee grinder, hand insertion, hot water dispenser, espresso, café crème, dual drain 70 mm – 190 mm,</p>
	<p>03 1400 0022 Presto 1 / N / PE, 50Hz, 230V, 2.2 kW, fuse protection building 10 A, water tank 4.5 L, 1 coffee grinder, hand insertion, hot water dispenser, espresso, café crème, dual drain 70 mm – -190 mm, amber lighting,</p>
	<p>03 1400 0023 Presto 1 / N / PE, 50Hz, 230V, 2.2 kW, fuse protection building 10 A, fixed water connection 1/2", drain DN 19, 1 coffee grinder, hand insertion, hot water dispenser, espresso, café crème, dual drain 70-190 mm, amber lighting,</p>
	<p>03 1400 0024 Presto 1 / N / PE, 50Hz, 230V, 2.2 kW, fuse protection building 10 A, integrated milk foamer, water tank 4.5 L, 1 coffee grinder, hand insertion, hot water dispenser, espresso, café crème, cappuccino, latte macchiato, dual drain 70 – -190 mm, amber lighting,</p>
	<p>03 1400 0025 Presto 1 / N / PE, 50Hz, 230V, 2.2 kW, fuse protection building 10 A, integrated milk foamer, fixed water connection 1/2", drain DN 19, 1 coffee grinder, hand insertion, hot water dispenser, espresso, café crème, cappuccino, latte macchiato, dual drain 70 – -190 mm, amber lighting,</p>
	<p>03 1400 0026 Presto 1 / N / PE, 50Hz, 230V, 2.2 kW, fuse protection building 10 A, integrated milk foamer, water tank 4.5 L, 2 coffee grinders, hand insertion, hot water dispenser, espresso, café crème, cappuccino, latte macchiato, dual drain 70 – -190 mm, amber lighting,</p>
	<p>03 1400 0027 Presto 1 / N / PE, 50Hz, 230V, 2.2 kW, fuse protection building 10 A, integrated milk foamer, fixed water connection 1/2", drain DN 19, 2 coffee grinders, hand insertion, hot water dispenser, espresso, café crème, cappuccino, latte macchiato, dual drain 70 – -190 mm, amber lighting,</p>
	<p>03 1400 0028 Presto 1 / N / PE, 50Hz, 230V, 2.2 kW, fuse protection building 10 A, integrated milk foamer, water tank 4.5 L, 2 coffee grinders, 1 chocolate powder dispenser, hot water dispenser, espresso, café crème, cappuccino, latte macchiato, chococcino, drinking chocolate, dual drain 70-190 mm, amber lighting,</p>
	<p>03 1400 0029 Presto 1 / N / PE, 50Hz, 230V, 2.2 kW, fuse protection building 10 A, integrated milk foamer, fixed water connection 1/2", drain DN 19, 2 coffee grinders, 1 chocolate powder dispenser, hot water dispenser, espresso, café crème, cappuccino, latte macchiato, chococcino, drinking chocolate, dual drain 70-190 mm, amber lighting,</p>
	<p>03 1400 0030 Presto 1 / N / PE, 50Hz, 230V, 2.2 kW, fuse protection building 10 A, water tank 4.5 L, 2 coffee grinders, 1 milk powder dispenser, hot water dispenser, espresso, café crème, cappuccino, latte macchiato, dual drain 70-190 mm, amber lighting,</p>
	<p>03 1400 0031 Presto 1 / N / PE, 50Hz, 230V, 2.2 kW, fuse protection building 10 A, fixed water connection 1/2", drain DN 19, 2 coffee grinders, 1 milk powder dispenser, hot water dispenser, espresso, café crème, cappuccino, latte macchiato, dual drain 70-190 mm, amber lighting,</p>
	<p>03 1400 0032 Presto 1 / N / PE, 50Hz, 230V, 2.2 kW, fuse protection building 10 A, water tank 4.5 L, 1 coffee grinder, 1 milk powder dispenser, hand insertion, hot water dispenser, espresso, café crème, cappuccino, latte macchiato, dual drain 70-190 mm, amber lighting,</p>
	<p>03 1400 0033 Presto 1 / N / PE, 50Hz, 230V, 2.2 kW, fuse protection building 10 A, fixed water connection 1/2", drain DN 19, 1 coffee grinder, 1 milk powder dispenser, hand insertion, hot water dispenser, espresso, café crème, cappuccino, latte macchiato, dual drain 70-190 mm, amber lighting,</p>
	<p>03 1400 0034 Presto 1 / N / PE, 50Hz, 230V, 2.2 kW, fuse protection building 10 A, integrated milk foamer, water tank 4.5 L, 1 coffee grinder, 1 chocolate powder dispenser, hand insertion, hot water dispenser, espresso, café crème, cappuccino, latte macchiato, chococcino, drinking chocolate, dual drain 70-190 mm, amber lighting,</p>
	<p>03 1400 0035 Presto 1 / N / PE, 50Hz, 230V, 2.2 kW, fuse protection building 10 A, integrated milk foamer, fixed water connection 1/2", drain DN 19, 1 coffee grinders, 1 chocolate powder dispenser, hand insertion, hot water dispenser, espresso, café crème, cappuccino, latte macchiato, chococcino, drinking chocolate, chococcino, dual drain 70-190 mm, amber lighting,</p>

WMF UNITED KINGDOM LIMITED

31 Riverside Way, Uxbridge

Middlesex UE8 2YF

Internet: <http://www.wmf.uk.com>

Phone 01895 816106

Fax 01895 81610

E-mail: service@wmf.uk.com

WMF COFFEE MACHINES

WMF Planning Info Presto Twintopping

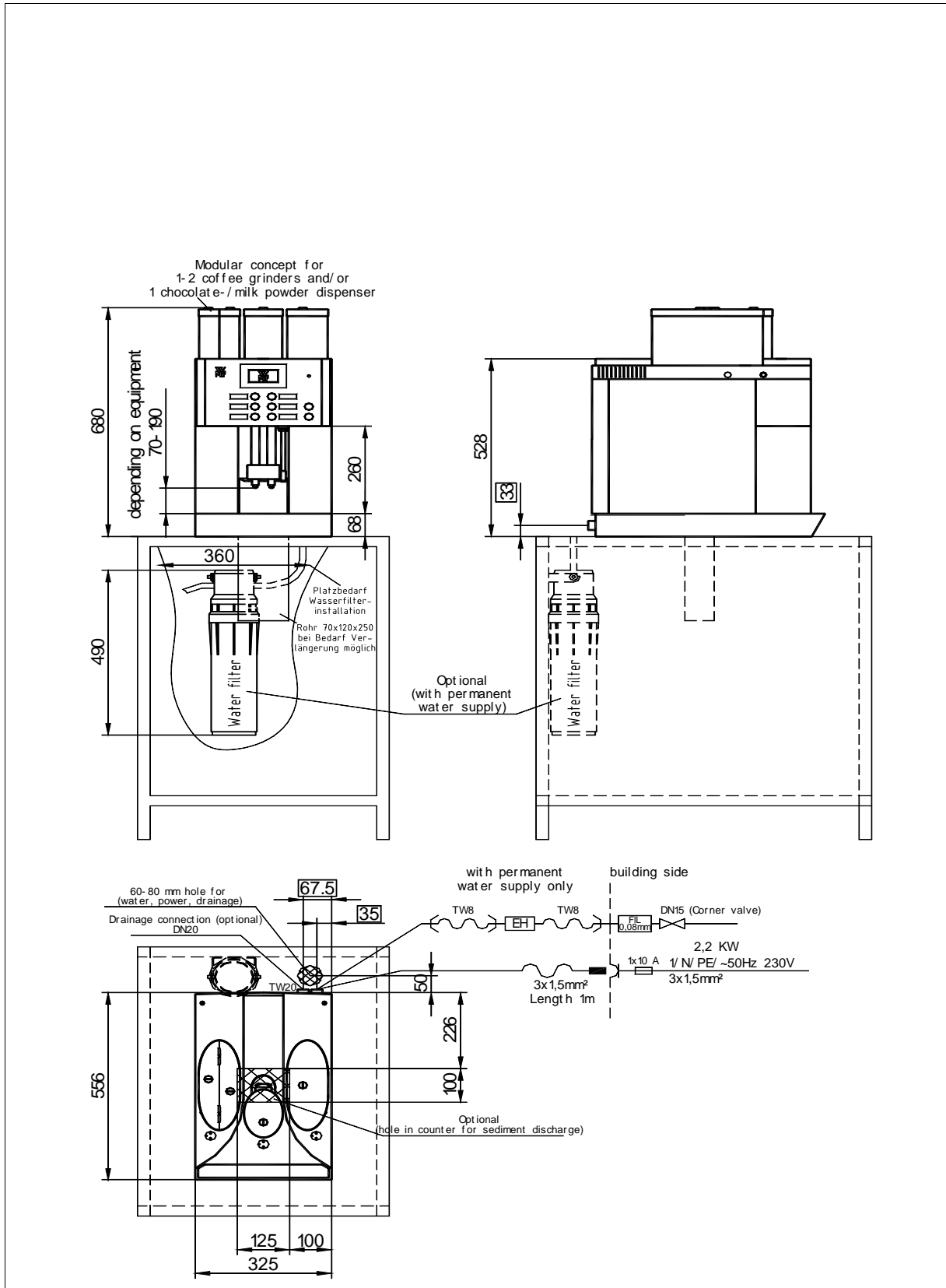

WMF UNITED KINGDOM LIMITED

31 Riverside Way, Uxbridge

Middlesex UE8 2YF

Internet: <http://www.wmf.uk.com>

Phone 01895 816106

Fax 01895 81610

E-mail: service@wmf.uk.com

WMF COFFEE MACHINES

Data sheet for Presto Twintopping

The article numbers in the table represent only a cross-section of the complete range of articles

The WMF Presto series is a modular system and can be customised for the requirements of the customer.

03 1400 0659 Presto Twintopping, 1 / N / PE, 50Hz, 230V, 2.2 kW, fuse protection building 10 A, fixed water connection 1/2", drain DN 19, 1 Twintopping container, lockable, 2 chambers 0.5 kg each (for milk and drinking chocolate powder topping), 1 coffee grinder, lockable, capacity 1 kg, 1 coffee grinder, lockable, capacity 0.5 kg, hot water dispenser, espresso, café crème, cappuccino, latte macchiato, chococcino, drinking chocolate, dual drain 70-190 mm, **amber lighting**

03 1400 0696 Presto Twintopping, 1 / N / PE, 50Hz, 230V, 2.2 kW, fuse protection building 10 A, fixed water connection 1/2", drain DN 19, 1 Twintopping container, lockable, 2 chambers 0.5 kg each (for milk and drinking chocolate powder topping), 1 coffee grinder, lockable, capacity 1 kg, hot water dispenser, espresso, café crème, cappuccino, latte macchiato, chococcino, drinking chocolate, dual drain 70-190 mm, **amber lighting**

WMF UNITED KINGDOM LIMITED

31 Riverside Way, Uxbridge
Middlesex UE8 2YF
Internet: <http://www.wmf.uk.com>

Phone 01895 816106
Fax 01895 81610
E-mail: service@wmf.uk.com

WMF COFFEE MACHINES

Data sheet for Presto Twintopping

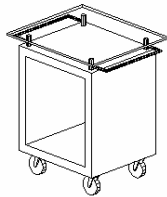
Brewing process:	specialty coffees and drinking chocolate with and without milk or milk powder topping Drinking chocolate made of chocolate powder, hot water and addition of milk.
Daily output:	max. 100 cups of specialty coffees with and without added milk or milk foam, 10 L hot water total output per day
Option:	 <p>„Twintopping“ (for chocolate and/or milk topping powder) with 2 chambers 0.5 kg each, lockable bean container 1 kg, „Aquaflex“ switchable water connection types for tank or fixed water connection operation, steam dispenser, integrated thermoelectric milk cooler, indirect LED-lighting in various colours, with fixed water connection water preparation filter (dimensions 126 mm Ø x 490 mm height), drainage connection DN 19,</p> <p>Mobile trolley only for WMF Presto series, (dimensions W850xH970xD685 mm) with four castors, two with brake,</p> <p>03 9171 0001 Basic trolley, powder-coated steel frame, with safety glass plate and handle and edge protector 03 9171 2001 Basic trolley with perforated plate panels, powder-coated steel frame, with safety glass plate and handle and edge protector 03 917110001 Basic trolley with plastic panels and lighting, powder-coated steel frame, with safety glass plate and handle and edge protector, 1 / N / PE, 50Hz, 230V, including multiple socket for direct coffee machine connection, 03 9171 9001 Hanging basket (optional) maximum 3 per trolley,</p>
Option:	tank filter 33 2332 5000 for WMF Presto with water tank. For optimising water quality and reduction of calcification
Accessories:	multitool, cleaning brush, basic equipment decalcifier, cleaning tablets, milk cleaner
Degree of protection:	IPX0
Protection class:	Protection class I
Perceptible heat emission:	0.11 kWh/h in standby mode
Perceptible heat emission:	2.11 kWh/h in maximum mode
Continuous sound pressure level (Lpa)	< 70 dB (A)
Water connection:	DN 15, (3/8“) e.g. corner valve
Flow pressure:	with fixed water connection at least 0.2 MPa (2.0 bar), at 2 L min.
Miscellaneous:	coffee machine with dry residue discharge into an integrated drawer or optional with sediment discharge into a building-side container (sediment discharge can be installed later, from ca. manufacturing date March 2006, Presto serial no. ca. > 4500)
Drain:	drip trough without drain. Optional drain DN 19, gradient at least 2%
Empty weight:	ca. 35-40 kg



WMF UNITED KINGDOM LIMITED

31 Riverside Way, Uxbridge
 Middlesex UE8 2YF
 Internet: <http://www.wmf.uk.com>

Phone 01895 816106
 Fax 01895 81610
 E-mail: service@wmf.uk.com

WMF COFFEE MACHINES

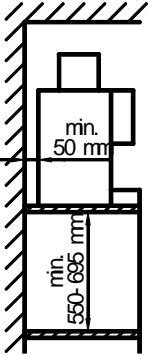
Data sheet for Presto Twintopping

<p>Installation clearances:</p> 	<p>For the installation a minimum clearance of 50 mm to the back wall and at the sides to walls or other non-WMF equipment is required for functional, service and safety reasons.</p> <p>A clear height of about 1100 mm from the top of the installation area is required. The height of the installation area from the top of the floor should be at least 850 mm. Installation of accessories underneath the unit (such as water filter) requires sufficient space for the water filter (126 mm diameter and 490 mm height).</p> <p>If the connections of the machine are down through the counter, please also consider the space required by the connection lines, which may restrict the usable space in the substructure.</p>
<p>Electrical connection:</p>	<p>The following specifications for the electrical connection and the cited standards are applicable for connecting machines in EU countries. If applicable, additional national regulations must be observed. Outside the EU the acceptance of the cited standards must be checked by the persons who market the machines.</p> <p>The building electrical system must comply with IEC 364. For increased safety the device should be protected by an earth-leakage circuit breaker with 30 mA rated fault current (EN 61008). A standard electrical outlet compliant with EN 60309 must be installed near the device or 30 cm below the top of the counter at the back or side of the undercounter structure for a single-phase connection. If the power connection cord of this device has been damaged, it must be replaced by our customer service or by a similarly qualified person. If the machine is permanently connected to the building power supply, a circuit breaker that disconnected all poles (main switch) in accordance with EN 60947 must be installed with at least 3 mm contact separation must be installed to protect the machine; the disconnecting device is recommended for a flexible connection. The power cord must not be in contact with hot objects. The electrical outlet is part of the building installation. The machine must not be installed with a fixed building connection when used with a trolley (mobile station).</p> <p><u>Important information:</u></p> <p>To prevent any interference with our shielded data lines by equipotential currents between the devices, an additional equipotential bonding should be installed for devices connected to an accounting system. (See IEC 364)</p>
<p>Water feed and drainage:</p>	<p>A sufficiently large, easily accessible stop cock (preferably a ball valve) and a dirt filter with a 0.080 mm mesh must be installed in the water pipe under the counter.</p> <p>If there is a drainage connection, the drain must be installed at the rear panel of the bottom cupboard 50 cm from the top of the counter.</p> <p>A pipe syphon must be installed in the vented drainage pipe. (Fit hose connection in the funnel with a hose ring holder) The WMF-specific conditions for water, power and effluent must be observed at all times.</p> <p>For the connection from below through the counter an opening is required in accordance with the drawing (see elevation drawing) or a hole approx. 80 to 120 mm in diameter. Alternatively the connections for electricity, water and drainage can be taken through the body of the machine from the back in the indicated  area (see the elevation and side view).</p> <p>If the water contains more than 5 ppm carbonate, a WMF water filter must be installed.</p> <p>CAUTION: The static water pressure must not exceed 0.6 MPa (6 bar).</p>

WMF UNITED KINGDOM LIMITED

31 Riverside Way, Uxbridge

Middlesex UE8 2YF

Internet: <http://www.wmf.uk.com>

Phone 01895 816106

Fax 01895 81610

E-mail: service@wmf.uk.com